

Operating Instructions

Evaluation Unit AE12 and Rope Load Sensor LS1 & LS2

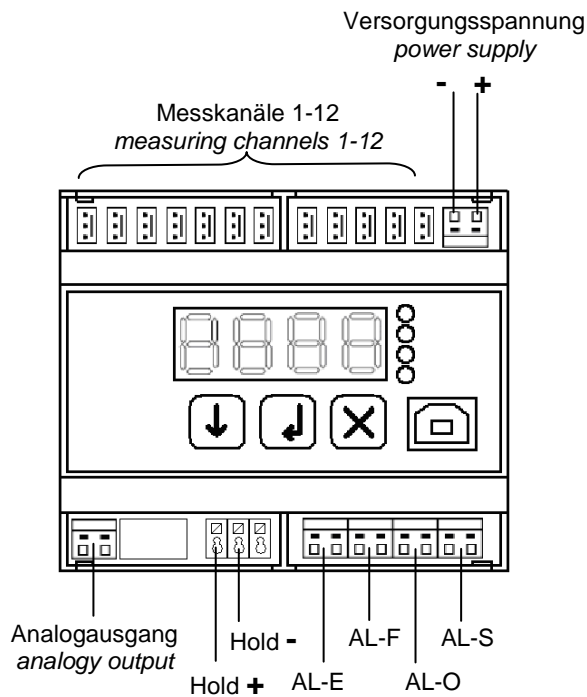

1. Dimensions

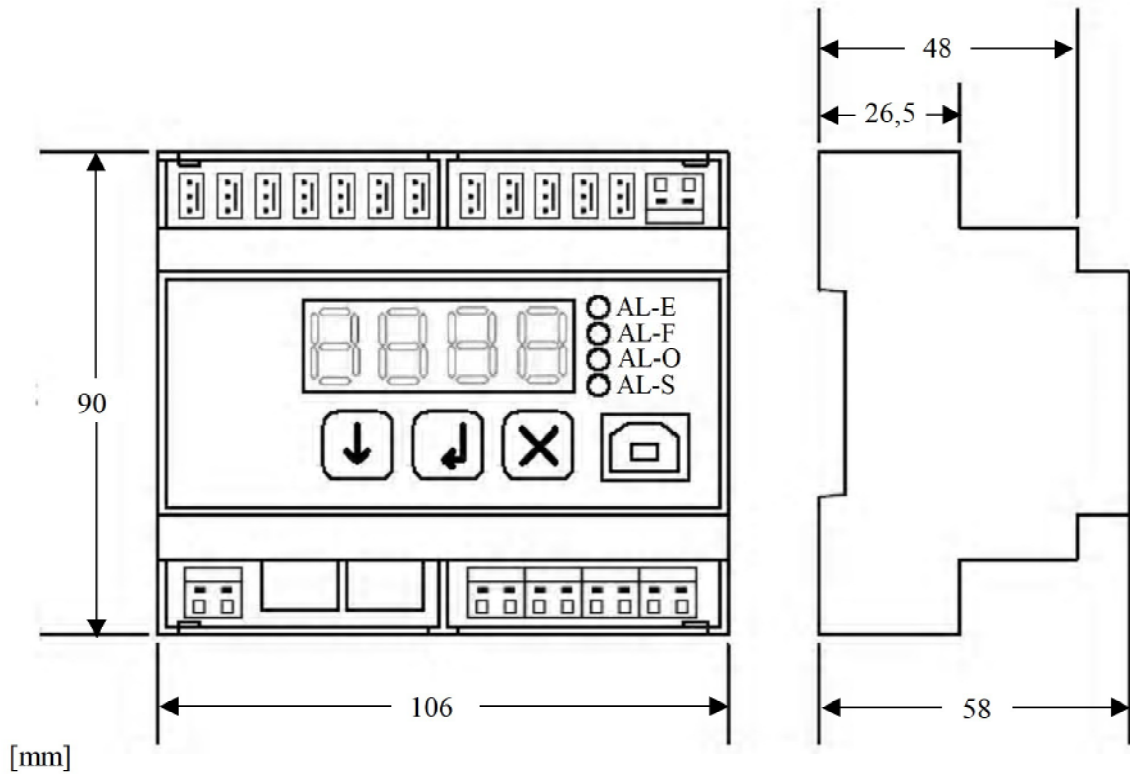

2. Connection diagram

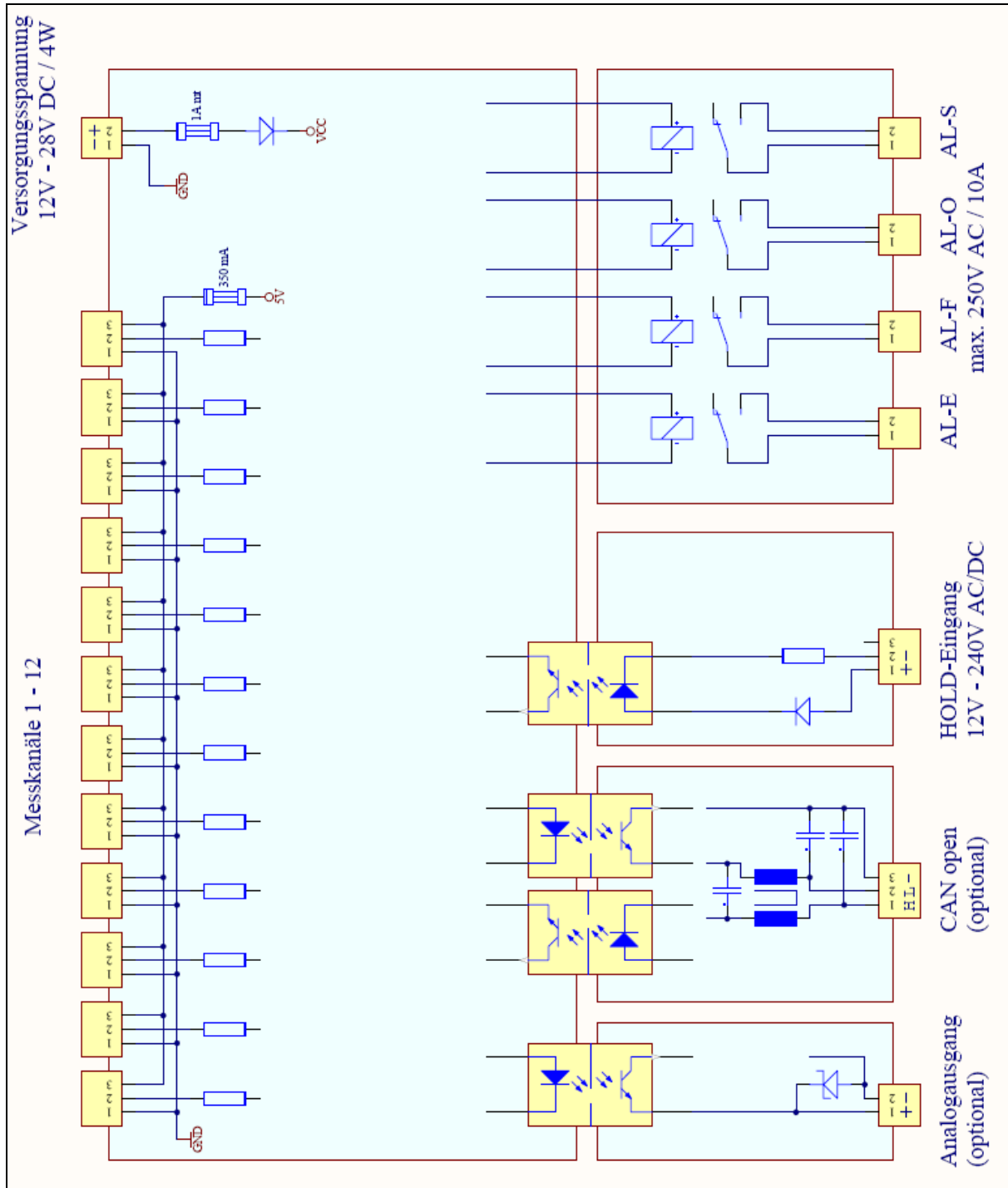

3. Description of alarm relays

AL-E (Empty load relay)

Change of state on falling below the load programmed in **AL-E**.

AL-F (Full load relay)

Change of state on exceeding the load programmed in **AL-F**.

AL-O (Overload relay)

Change of state on exceeding the load programmed in **AL-o**.

AL-S (Slack rope and rope difference relay)

Change of state as soon as the car empty load falls below the value of the load programmed in **AL-S**

AND

Change of state as soon as one of the ropes deviates from the average of all ropes at least by the load programmed in **AL-r**.

Note:

The working procedure of the relays as a make or break contact can be changed for each alarm output using the **CONF** parameter.

4. HOLD function

The HOLD input responds for alternating and direct voltages between 12 V to 230 V. During the elevator travel the measured loads can heavily fluctuate (friction in the rails etc.). As long as a voltage (e. g. the travel signal) between 12 to 230 V is applied at the HOLD input the alarm output through the alarm relays does not take place.

5. Access to the parameters

The unit is equipped with a menu by which the individual setting parameters can be reached.



By pressing this key the individual menu items are cycled through. If one menu item has been selected, the key is used for the navigation of the submenus. Within the individual parameters the value can be changed by this key.



Using this key the currently displayed menu item is selected, or in the parameters the set value is adopted.







 Using this key the new selected menu items and parameter settings are cancelled. Repeatedly pressing this key finally leads to the display of the total weight.

Note:

After one minute without operation the unit automatically returns to the display of the total weight, independent of the menu item that was previously selected.

After 10 minutes without operation the unit switches to low consumption mode, i. e. the display switches off and can be reactivated on the next operation.

6. Change of a parameter





- 1.) Use the  key to display the parameter that is to be changed.
- 2.) Select the parameter using the  key.
- 3.) Use the  key to change the value of the currently flashing digit position.
Switch to the next position using the  key.
- 4.) After input of the final digit reuse the  key. Now the total value is flashing.
- 5.) Press the  key again in order to adopt the value.





7. Menu structure

0876 (4 digits in kg)	Weight indication
r0PE (rope)	Indication of the individual rope loads
rCnt (rope count)	Setting of the number of ropes / rope sensors
rFct (rope factor)	Adjustment of the rope suspension ratio
CEr0 (zero)	Zero point adjustment
AL-E (alarm empty)	Alarm phase Empty Load
AL-F (alarm full)	Alarm phase Full Load
AL-o (overload)	Alarm phase Overload
AL-S (alarm slack rope)	Alarm phase Slack Rope
AL-r (alarm rope load)	Alarm phase Rope Load Difference
dCov (DC out)	Adjustment of the analogue output (only relevant for the AE12 with analogue output)
Unit (unit)	Adjustment of the display weight unit
17C (Program version)	Version number

8. Indication of the individual rope loads

- a) Display the menu item **roPE** using  and select with the  key.
- b) On the display appears the weight in kg (e.g. **0 105**) alternating with the rope number **ro0 1** (rope 1).
- c) Switch between the individual ropes with  (up to the maximum number of ropes adjusted in **rCnt**).
- d) At any time you can leave the menu item with .

9. Adjustment of the number of rope sensors



- a) Select the menu item **rCnt** (rope count) using  and then press the  key.
- b) Follow the instructions under point 6 „Change of a parameter“ in order to adjust the correct number of rope sensors.
- c) At any time you can leave the menu item with .

Note:

It is absolutely necessary to adjust the correct number of rope sensors. Otherwise the AE12 will recognize that sensors are missing and will switch to the error mode in which all alarm relays will be activated.

10. Adjustment of the suspension ratio

In the case of multi-suspension you have to set the factor by which the rope loads are multiplied.



- a) Select the menu item **rFLt** (rope factor) with the  key and then press the  key.
- b) Follow the instructions under point 6 „Change of a parameter“ in order to adjust the correct factor.

Example: in the case of a 2 : 1 suspension you have to enter the factor **02**

- c) At any time you can leave the menu item with .

11. Zero point adjustment

With this function the total weight indicated on the AE12 unit is reduced by the empty weight of the car, i. e., in the case of an empty car the display shows 0 kg.

- a) Select the menu item **CEro** with the  key and then press . Now on the display **CEro** starts flashing.
- b) Please check that the car is really unloaded. After pressing the  key again a 10 second countdown will start. During this period of time the car weight must not be changed.
- c) Then the zero point is balanced

Note:

The function Slack Rope Alarm only functions with a balanced empty load of the car. Therefore, it is absolutely necessary that you make this zero point adjustment when using the slack rope alarm.

12. Alarm phases

The alarm phases correspond to the loading at which the relays change their state. In addition you may choose whether the individual relays work as make or break contact.

AL-E (Empty load relay)

Change of state on falling below the load programmed in **AL-E**.

AL-F (Full load relay)

Change of state on exceeding the load programmed in **AL-F**.

AL-O (Overload relay)



Change of state on exceeding the load programmed in **AL-o**.

AL-S (Slack rope)

Change of state as soon as the car empty load falls below the value of the load programmed in **AL-S**.

AL-r (Rope difference)

Change of state as soon as one of the ropes deviates from the average of all ropes at least by the load programmed in **AL-r**.

- a) Select the corresponding alarm phase with  and then press the  key.
- b) Now, with the  key you select between **LoAd** (load) and **CONF** (configuration).
- c) In **LoAd** you set the load switching threshold in kg.

In **CONF** you can select between **CLoS** (close) for the operating mode MAKE and **oPEn** (open) for the operating mode BREAK. The setting is only adopted after the second use of the  key (selection flashes after the first use)

13. Adjustment of the analogue output (optional)

At the parameter **d[ou]** you adjust the weight, at which the analogue output shall deliver the maximum output value of 10V or 20mA.

Under this menu item you have to adjust three parameters:

- At **LoAd** you select the weight at which the output shall deliver the maximum of 10 V or 20 mA.
- In **oFFS** you can switch a “live Zero” on or off. If you switch this option to **on** a measured rope load of 0 kg corresponds to an analogue output signal of 2 V or 4 mA. If the option is switched off with **oFF** a rope load of 0 kg corresponds to 0 V or 0 mA.
- In **tArA** you can select whether only the payload shall be output via the analogue output. (The precondition is that you have used the zero point adjustment **[Ero]**).

If you select the option **on**, only the payload is output. If the option is switched off with **oFF** the analogue output signal corresponds to the sum of payload plus the empty weight of the car.

14. Adjustment of the display unit

At **Un it** you can choose between three different weight units. All displayed weights and alarm thresholds are shown in the selected unit. All internal calculations are made in kg, therefore, rounding errors are possible.

You can select from these units:

- **Si** (SI) All weights are shown in *kg*.
- **tnSh** (tnSh) All weights are shown in *short tons* (1 S/T = 2000 lb).
- **tnL** (tnL) All weights are shown in *long tons* (1 L/T = 2240 lb).

15. Electrical Values

Power supply voltage	12 V – 28 V DC
Power consumption	max. 4 W (all Relays activated)
Fuse	1 A mT
HOLD input	12 V - 230 V AC/DC
Relay outputs	
max. Switching voltage	250 V AC
max. Starting current	15 A
max. Continuous current	10 A
max. Switching capacity (resistive load)	2500 W
max. Switching capacity (inductive load)	500 VA
min. Switching load DC	0.3 W
Analogue output (optional)	
galvanically isolated	yes
Voltage output (resistive load > 500 Ω)	2 V – 10 V or 0 V – 10 V
Current output (resistive load < 500 Ω)	4 mA – 20 mA or 0 mA – 20 mA

16. Change of a fuse

- Disconnect the AE12 from the power supply voltage.
- Remove the base plate from the unit rear side.
- Remove the circuit board from the housing.
- Change the fuse 1mA mT. You will find the fuse switch directly behind the terminals of the power supply voltage.

17. Error messages

All 4 alarm LED's light up

At least one load sensor has failed or the wrong number of sensors has been set under menu item **rCnt**.

Action:

Select menu item **rCnt** and verify the number of sensors set.

If this number has been set correctly and the error still exists, go to menu item **roPE** and verify the individual ropes. If **Err 1** is indicated, the relevant sensor has failed. If **Err 2** is indicated, the relevant sensor supplies too high a signal and is overloaded.

18. Installation of the LS1 & LS2 sensors

For each carrying rope one load sensor must be provided.

1.) Selection of the appropriate installation position

The point on the rope where the load sensor is installed must fulfil the following conditions:

- -During travel over the total lifting height the sensor must not make physical contact with any other components.
- -At the installation position selected the rope must run straight and be entirely undamaged.
- At the selected point there must not have been previous mechanical influences such as other rope sensors, multiple installations etc.
- -Between the cable joint and the load sensor there must be a minimum 10 cm of free rope.

2.) Insertion of the load sensor LS into the rope

Open the rope clamp with the M5 screw enough to allow the rope to lie in the groove of the load sensor over the total sensor length.

3.) Closing of the rope clamp

Tighten the M5 screw to 4 Nm

(verification: both lock washers are flattened, see photo).



4.) Connecting the sensor to the evaluation unit AE12

The load sensors LS1 must be connected to the AE12 starting with sensor socket 1 in the upper left corner of the housing:

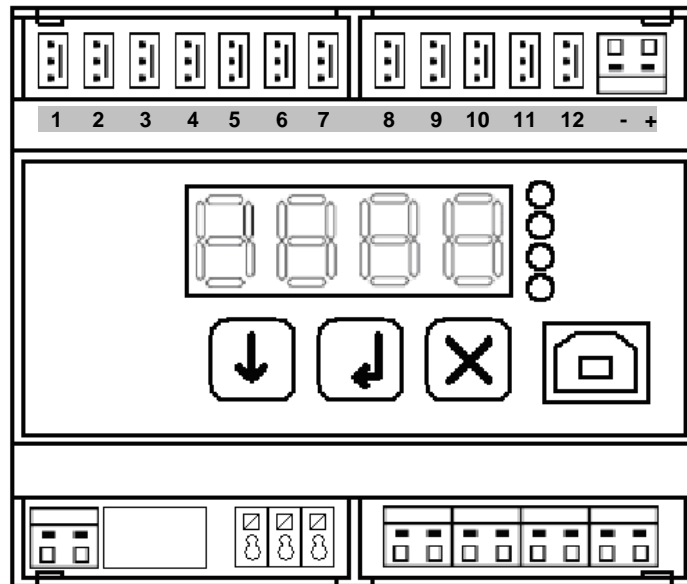

Repeat steps 1 to 4 for all sensors to be connected.

Note:





For an exact measurement result the sensor must only be clamped once onto the selected point of the rope.

19. Short operating instructions





1.) Install the evaluation unit AE12 in an appropriate location.

2.) Installation of the sensors (see point 18).



3.) Adjustment of the number of sensors (see point 9).

With  switch to menu item **rCnt** and adjust the number with  and . Press  twice to confirm the adjustment.

4.) Adjustment of the suspension factor, only necessary if it is not a 1:1 suspension (see point 10).

With  switch to menu item **rFct** and adjust the number with  and . Press  twice to confirm the adjustment.

5.) Adjustment of the alarm thresholds (see point 12).



With  and  choose the corresponding alarm phase. In

LoAd adjust with  and  the load switching threshold.

In **CONF** adjust the operating mode **CLoS** for make contact and **oPEn** for break contact.

Press  twice to confirm the adjustment.

6.) Carry out zero balancing of the unit with empty elevator (see point 11).

With  switch to menu item **CEro**. Press  twice and the countdown will start.

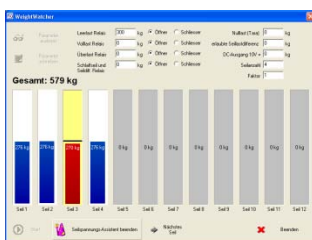

Note:

It also is possible to carry out all parameter settings of steps 3.) 4.) and 5.) and the **computer-aided rope adjustment** in comfort with our free of charge WeightWatcher Software using the USB interface of the AE12. You will find this software on our home page www.henning-gmbh.de at Software.

**Henning GmbH
Industriegebiet S5
Loher Str. 4+30
58332 Schwelm (Germany)**

**Tel.: +49 2336 9298-0
Fax.: +49 2336 9298-10
info@henning-gmbh.de
www.henning-gmbh.de**